

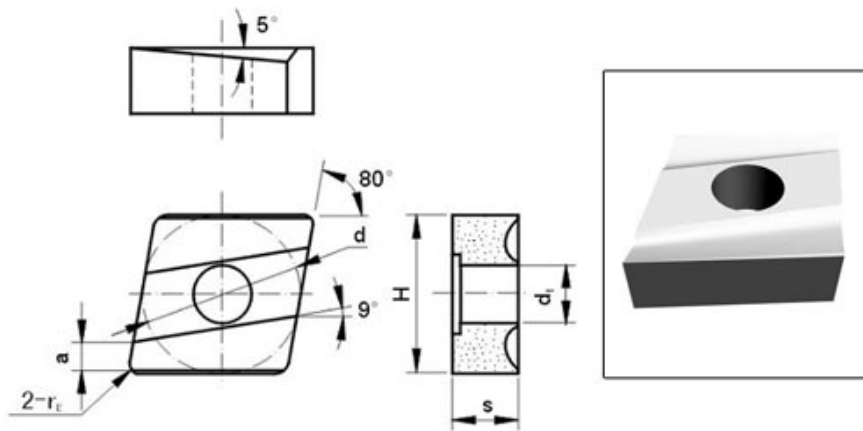

钨钢车削刀片-CL型



单位: mm

代号	d	s	re	H	a≈	d1
CTC-GC1005L	10.0	3.5	0.5	10.0	2.0	4.2
CTC-GC1305L	13.0	4.5	0.5	13.0	3.0	5.2
CTC-GC1610L	16.0	5.5	1.0	16.0	4.5	6.2
CTC-GC1910L	19.0	8.0	1.0	19.0	5.5	7.2
CTC-GC1005LL	10.0	3.5	0.5	10.0	2.0	4.2
CTC-GC1305LL	13.0	4.5	0.5	13.0	3.0	5.2
CTC-GC1610LL	16.0	5.5	1.0	16.0	4.5	6.2
CTC-GC1910LL	19.0	8.0	1.0	19.0	5.5	7.2

根据尺寸范围不同, 刀片毛坯内径公差为 ± 0.20 , 厚度公差为 ± 0.30 ,
 内切圆、宽度、高度公差为 ± 0.50 , 详情请咨询。